



5 St. Anne Street
 St. Albert, AB T8N 3Z9
 Phone: 780-459-1642
 Fax: 780-458-1974
 Email: development@stalbert.ca

CITY USE ONLY	
Application Fee	
Building Permit Deposit	
Safety Code Fee	
Total Fees	<input type="radio"/> Paid
Receipt No.	

APPLICATION FOR DEVELOPMENT PERMIT

PLEASE PRINT

I/We hereby make application under the provisions of the Land Use Bylaw to develop in accordance with the plans and information submitted, and which form a part of this application.

Municipal Address:	98 ELDRIDGE POINT, ST. ALBERT, AB, T8N8C4		
Legal Description:	Lot (Parcel) 47	Block 4	Plan 2422069
	Other legal description		
Development Proposed:	INSTALLATION OF WALL MOUNTED PERGOLA ON EXISTING BACK DECK.		
Applicant:	Name	ARVIN RAMNANAN	Daytime Phone
	Mailing Address	98 ELDRIDGE POINT	Email
	City	ST. ALBERT	Date (MM/DD/YYYY)
	Postal Code	T8N8C4	04/27/2026
Landowner:	Name	ARVIN RAMNANAN & VICKY RAMDATT-RAMNANAN	Daytime Phone
	Mailing Address	98 ELDRIDGE POINT	Email
	City	ST. ALBERT	Date (MM/DD/YYYY)
	Postal Code	T8N8C4	04/27/2026

By signing this form, the applicant declares that the development identified in this Application will be conducted in accordance with the plans submitted and, upon approval, will adhere to the conditions and provisions of the Land Use Bylaw. The applicant further declares that they WILL NOTIFY the Development Authority of any proposed changes to the plans submitted with this Application.

 Digitally signed by Arvin S. Ramnanan
 Date: 2026.04.27 13:48:03-06'00'

Signature of Applicant

2026.04.27

Date of Application

IMPORTANT NOTICE: This Application does not permit you to commence any development until such time as the Development Authority has issued a Development Permit. It is understood that if this application is approved or refused by the Development Officer, it may be appealed to the Subdivision & Development Appeal Board if such appeal is made within 21 days from the notice of decision date. It is further understood that the Subdivision & Development Appeal Board may confirm, revoke or vary the development permit or any condition as a result of such an appeal being duly filed, and that any work undertaken prior to the expiry of the appeal period or the determination of the appeal by the Subdivision & Development Appeal Board, whichever case applies, is entirely at the applicant's risk.

Collection and Use of Personal Information

Personal information is collected under the authority of s. (33) of the Freedom of Information and Protection of Privacy Act. This information will be used for the purpose of processing permit applications. If you have any questions about the collection, use, or disclosure of this information, contact the Director of Planning and Development, St. Albert at 780-459-1642.



Building Inspection Services

5 St. Anne Street
St. Albert AB T8N 3Z9
Phone: (780) 418-6601
Fax: (780) 458-1974
E-mail: BIS@stalbert.ca

<i>Collection and use of personal information</i> <i>The information on this form is collected by the City of St. Albert for the purpose of processing permit applications. The use, retention and/or disclosure of such information shall be in strict compliance with the Freedom of Information and Protection of Privacy Act (and any other legislation governing the use and disclosure of information).</i>	Building Permit Deposit <input type="checkbox"/>	
	Fee <input type="checkbox"/>	
	Safety Code Fee	
	Total Fees	
Paid By:		
Receipt #:		

BUILDING PERMIT APPLICATION

NEW CONSTRUCTION / IMPROVEMENT / CHANGE OF USE / OCCUPANCY / DEMOLITION

Municipal Address of Property 98 ELDRIDGE POINT Unit # N/A

Description of Property: Lot(s) 47 Block 4 Plan 2422069

Business Name N/A

Project BACK DECK PERGOLA INSTALLATION Occupancy Date 10 / 18 / 2026

Previous Use SINGLE FAMILY DWELLING

Applicant Details

Applicant Name ARVIN RAMNANAN

Mailing Address 98 ELDRIDGE POINT

City ST. ALBERT Province AB Postal Code _____

Contact [REDACTED] Phone [REDACTED] * Email [REDACTED] *Mandatory Field

Interest of Applicant (e.g. owner, contractor, architect) OWNER Bus. Lic. No. _____

Property Owner Name ARVIN RAMNANAN & VICKY RAMDATT-RAMNANAN Phone [REDACTED]

Project Details

New Construction Interior / Exterior Alterations / Addition Change of Use / Occupancy Demolition

Total Floor Area Being Occupied 100SQFT *Construction Value of Work \$ 3000

Description of work to be completed INSTALLATION OF A WALL-MOUNTED PERGOLA TO BACK DECK OF HOUSE.

Does Project Involve:

Plumbing Work? Yes Contractor _____ Phone _____

Gas Work? Yes Contractor _____ Phone _____

Heating & Ventilation? Yes Contractor _____ Phone _____

Electrical Work? Yes Contractor _____ Phone _____

Fire Sprinkler Work? Yes Contractor _____ Phone _____

Additional information or drawings may be required as considered necessary to make a decision on your application.

Note: A site plan and floor plan or construction drawings must be submitted with all applications.

Note: In the event any work is commenced prior to issuance of an applicable permit, the fees shall be DOUBLED. Any work covered prior to inspection shall be uncovered at the inspector's discretion.

Signature X  Digitally signed by Arvin S. Ramnanan Date: 2026.04.27 13:48:24-06'00' Date 2026.04.27



5 St. Anne Street
 St. Albert, AB T8N 3Z9
 Phone: 780-459-1642
 Development email: development@stalbert.ca
 Business Licensing email: licensing@stalbert.ca | [Contact Business Licensing](#)

CITY OF ST. ALBERT - OWNER'S AUTHORIZATION

Date: 2026 April 27
 File No.: _____

MUNICIPAL GOVERNMENT ACT, RSA, 2000, CHAPTER M-26

(PLEASE PRINT)

I, ARVIN RAMNANAN

(owner's name)

of N/A

(company, if applicable)

being the registered owner of 98 ELDRIDGE POINT, ST. ALBERT, T8N8C4

(civic address)

LOT 47, BLOCK 4, PLAN 2422069

(legal description)

do hereby allow SELF

(applicant – please print)

To make application for:

Development Permit
 (Includes, but is not limited to: Sign Permits, Change of Use and/or New Occupancy, etc.)

(other description if required)

Permits issued under the Safety Codes Act (Building, Electrical, Plumbing, Gas & HVAC)

Business Licence Application (whether as a lessee, contractor, agent or resident)

ARVIN RAMNANAN

(owner's name – please print)



(owner's signature)
Digitally signed by Arvin S. Ramnanan
 Date: 2026.04.27 13:50:15-06'00'

ARVIN RAMNANAN

(applicant's name – please print)

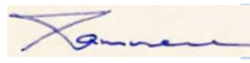

(applicant's signature)
Digitally signed by Arvin S. Ramnanan
 Date: 2026.04.27 13:50:38-06'00'

Collection and use of personal information

Personal information is collected under the authority of s. (33) of the Freedom of Information and Protection of Privacy Act (FOIP) and is managed in accordance with the provisions of FOIP. This information will be used for the purposes listed above. If you have any questions about the collection, use or disclosure of this information, contact the Director of Planning and Development, St. Albert at 780-459-1642.



MANUEL D'INSTRUCTIONS INSTRUCTION MANUAL

Nikko 10x10 Pergola murale en aluminium
Nikko 10 x10 Aluminum wall mounted Pergola

sku:PAW1010		
-------------	--	--

**DO NOT DESTROY THE BOXES UNTIL COMPLETELY ASSEMBLED
FOR FUTURE REFERENCE,
TAKE PICTURES OF ALL SIX SIDES OF EACH OF THE BOXES UPON RECEIPT.
PLEASE VERIFY THE CONTENT OF EACH BOX AGAINST THE LIST OF PARTS**

10ft x 10ft / 3m x 3m Pergola

Instruction Manual

IMPORTANT: RETAIN FOR FUTURE REFERENCE, READ CAREFULLY

Consult with your local governing authority / local municipal codes regarding installation of temporary structures before purchase or assembly. Some jurisdictions may require permits for, or otherwise regulate, installation and use.

For assistance with assembly, installation, parts, or customer service, contact Gazebo Penguin Customer Service Department at the numbers listed below (English & French, Mon-Fri 8:00 AM to 4:00 PM EST):

Montreal: (514) 276-3485

Elsewhere in Canada and the US: 1-800-737-7174

WARNING:

- For outdoor use.
- Snow should be regularly cleared from the roof and not allowed to accumulate.
- Retain your **proof of purchase** for warranty purposes. Also keep the **original boxes** until the installation is complete and correct.
- The unit may take more than 4 hours and 3 people are required for this assembly.



PRIOR TO ASSEMBLY:

- Please don't destroy boxes until completely assembled.
- The foundation must be level, flat, and solid, such as concrete or asphalt.
- Keep away from overhead utility lines, tree branches, and other structures.
- Check for underground pipes or wires if digging or drilling is required.
- Do not install near roof lines or other structures that could shed snow, ice, or excessive rain run-off onto the roof top.
- Assemble the structure as close to its final location as possible.
- It is recommended to wear safety gloves, safety glasses, and hard hats for installation.
- Do not hang from, climb on, or stand on the structure or roof.
- Before assembly, read instructions and check that all parts are present in the boxes. If any parts are missing, refer to warranty information.
- A 6ft (1.8m) stepladder, Phillips screwdriver, tape measure, level, mallet, and a tarp to place parts on will be required for assembly (not included).
- Remove top protective film from roof panels prior to assembly; DO NOT remove bottom protective film until ready to insert roof panels, so as to identify which side is on top.

ANCHORING INSTRUCTIONS:

- Proper anchoring of the frame to the base and the wall is required for safety.
- Any structure not anchored securely has the potential to fly away during high wind causing damage and safety hazard.
- How the item is anchored, and the hardware and tools required, will vary based upon the set up location and are not provided.
- Please check with your local hardware store if for the appropriate anchors for your surface.
- Do not anchor to pavers / pavement slabs because they are not a solid foundation.
- Periodically check the anchors to ensure they remain secure

CARE AND MAINTENANCE:











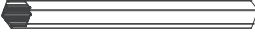

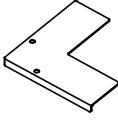

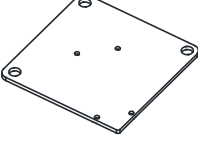

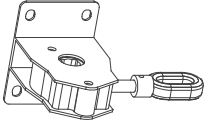

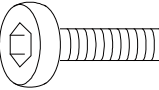
- In case of a defective or damaged part, or for any other questions concerning the product, please contact the manufacturer directly.
- Please have the parts list and part numbers on hand when ordering or requesting replacement parts.

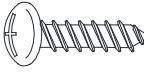

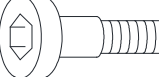

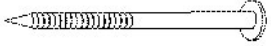

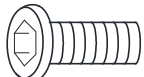

ROOF PANELS:

- Gently clean with an environmentally-friendly soap solution and water using a sponge or washcloth.
- Do not use abrasive materials, wire brushes, chemicals, harsh cleaners, or bleach.
- Rinse using a garden hose and air dry. If removed, ensure thoroughly dry prior to storage.
- Do not use pressure washer.

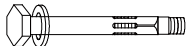
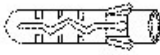
STRUCTURE:

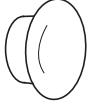
- Gently clean with an environmentally-friendly soap solution and water using a sponge or washcloth.
- Do not use abrasive materials, wire brushes, chemicals, harsh cleaners, or bleach.
- Rinse using a garden hose and air dry.
- Do not use pressure washer.
- If there are nicks, chips, and/or scratches see the part # of the paint in the parts list to obtain a matching touch-up paint.

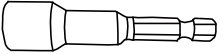
PART	PACKED IN BOX	QTY	DIAGRAM	PART	PACKED IN BOX	QTY	DIAGRAM
23-185 Corner Post A	1	2		23-199 Crank H3	2	1	
23-186 Left Lintel B	2	1		23-200 Cap Liner I	1	2	
23-187 Right Lintel C	2	1		23-201 Base Plate J	1	2	
23-188 Front Lintel D	2	1		23-204 Spinners M	1	2	
23-191 Middle Lintel E	2	1		23-205 Bolt AA	2	26	 M6*15MM
23-192 Rear Lintel F	2	1		23-206 Bolt BB	2	4	 M5*15MM
23-224 Louver G	3	42		23-207 Bolt CC	2	4	 M6*10MM
23-225 Cover Plate G1	3	2		23-208 Screws DD	2	6	 M6*65MM
23-197 Connecting Rod H1	2	2		23-209 Bolt EE	2	168	 M5*8MM
23-226 Connecting Rod H2	2	2		23-210 Nut FF	2	4	 M6

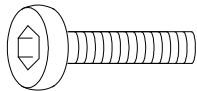
PART	PACKED IN BOX	QTY	DIAGRAM	PART	PACKED IN BOX	QTY	DIAGRAM
23-211 M8 Washer GG	2	4		23-217 Allen wrench MM	2	1	 6#
23-212 M6 Washer HH	2	44		23-218 Bolt NN	2	6	
23-213 Plastic Plug II	2	6		23-219 Bolt OO	2	8	 M5*25MM
23-214 Wrench JJ	2	1		23-220 Cap PP	2	6	
23-215 Allen wrench KK	2	1		23-221 Sleeve QQ	2	1	
23-216 Allen wrench LL	2	1	 4#	23-223 Allen wrench RR	2	1	 3#
23-222 Bolt SS	2	8	 M6*20MM				

Step 1

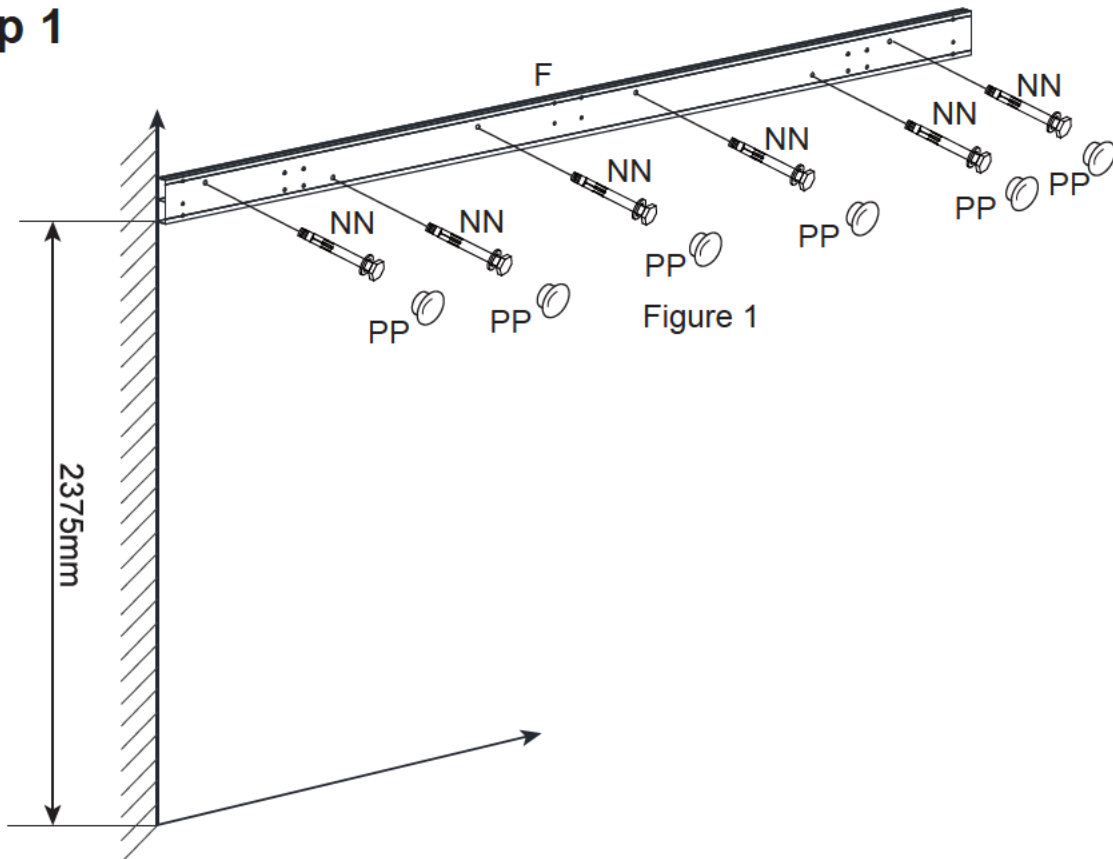

Figure 1

1. Adjust the bottom height of the Rear Lintel (F) to 2375MM above the horizontal floor level and secure the Rear Lintel (F) to the wall with Bolts (NN). Then cover the holes with Caps (PP). See Figure 1.

Step 2

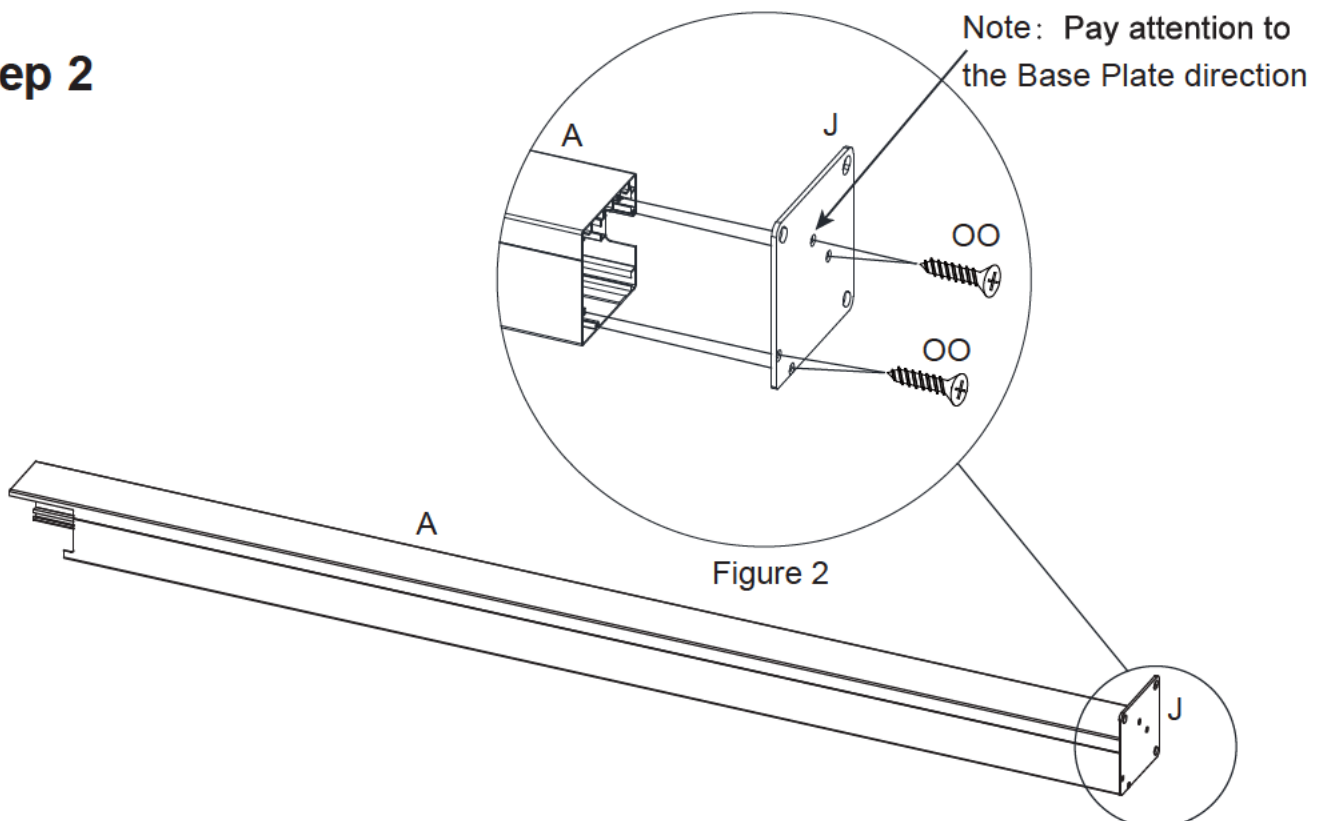

Figure 2

2. Connect the Base Plate (J) and Post (A) together and secure with Bolts (OO). See Figure 2.

Step 3

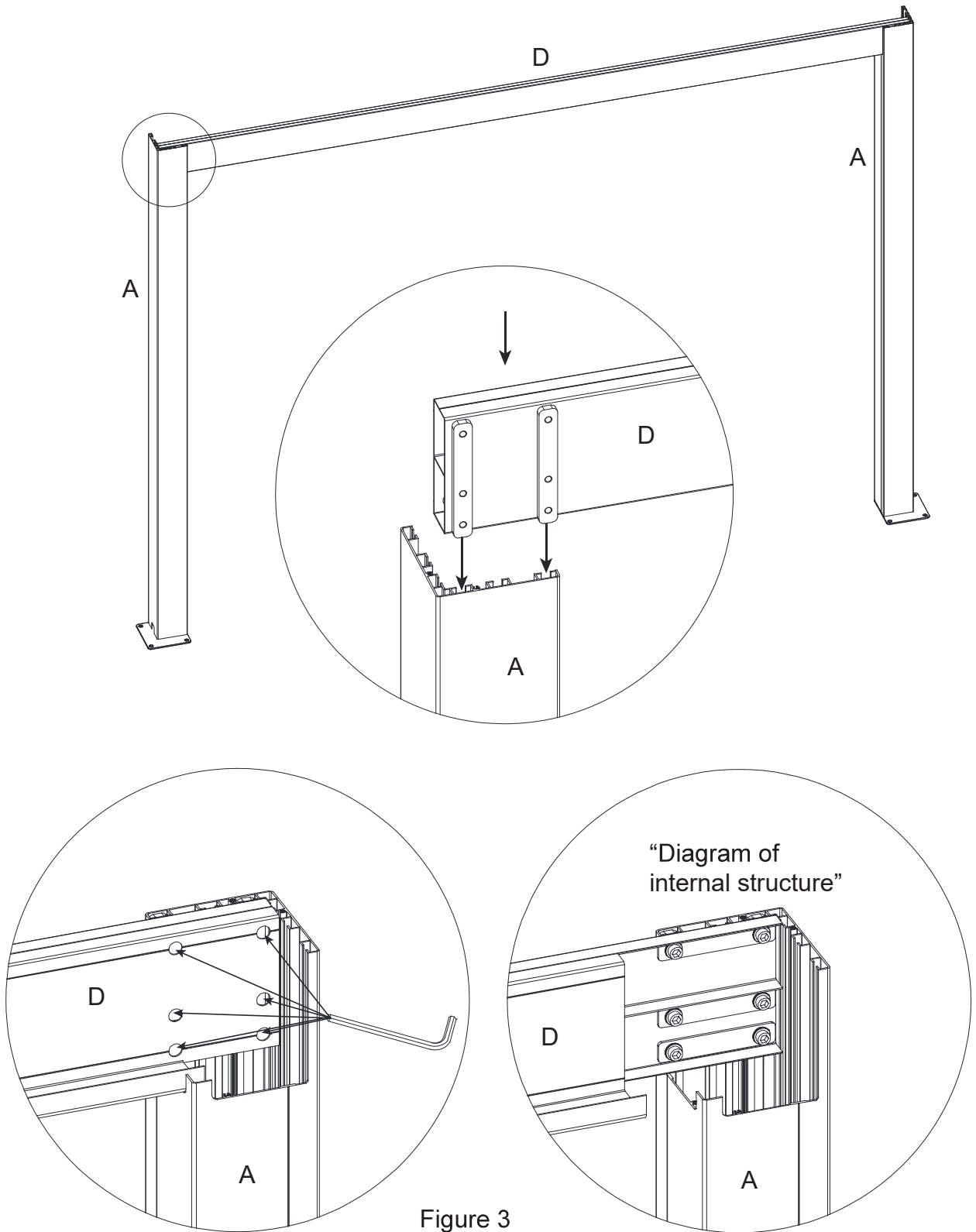

Figure 3

3. Slide the ends of the Front Lintel (D) into the groove in the Post (A) and tighten Diagram of internal structure the bolts in the Front Lintel (D) with the Wrench. See Figure 3.

Step 4

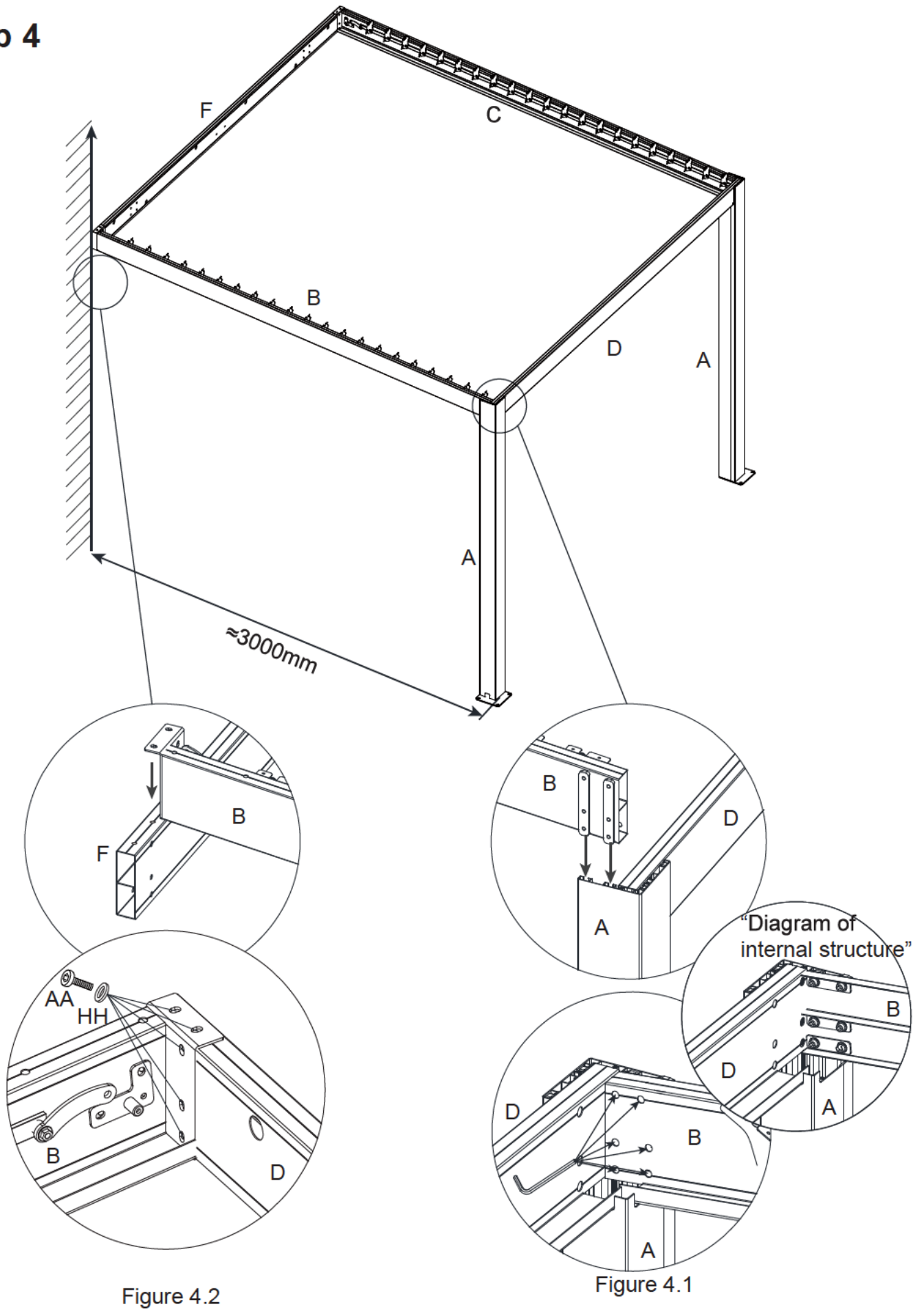

Figure 4.2

Figure 4.1

4. Slide the end of the side Lintel (B) into the groove in the post (A) and tighten the bolts in the post (A) with the wrench (JJ). See Figure 4.1-4.2. Tighten the bolts at the end of Lintel (B) and Wall Lintel (F). Repeat the same steps with Lintel (C).

Step 5

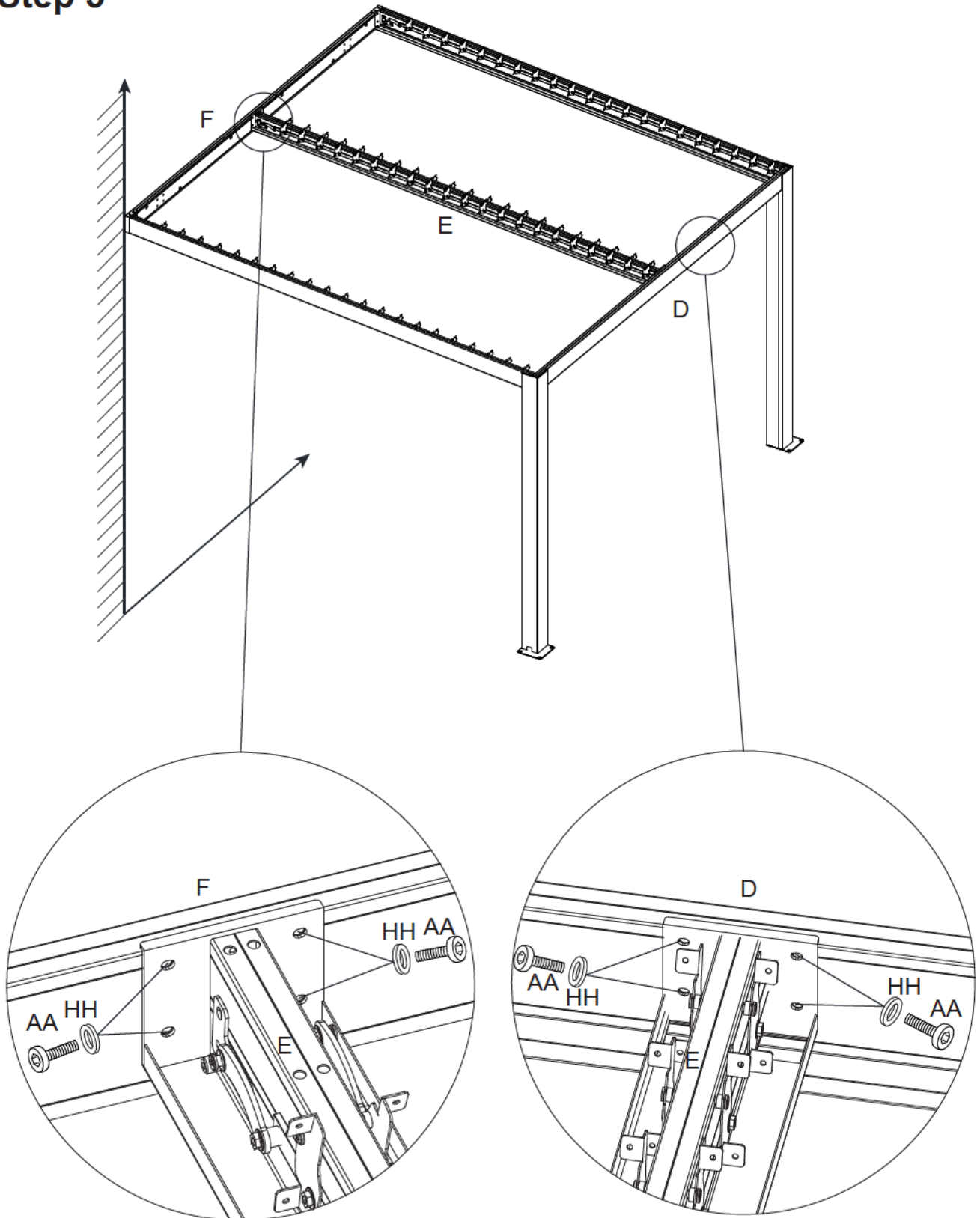

Figure 5

5. Connect the Middle Lintel (E) to the Front Lintel (D) on one end and the other end to the Rear Lintel (F), securing them together with Bolts (AA) and Spacers (HH). See Figure 5.

Step 6

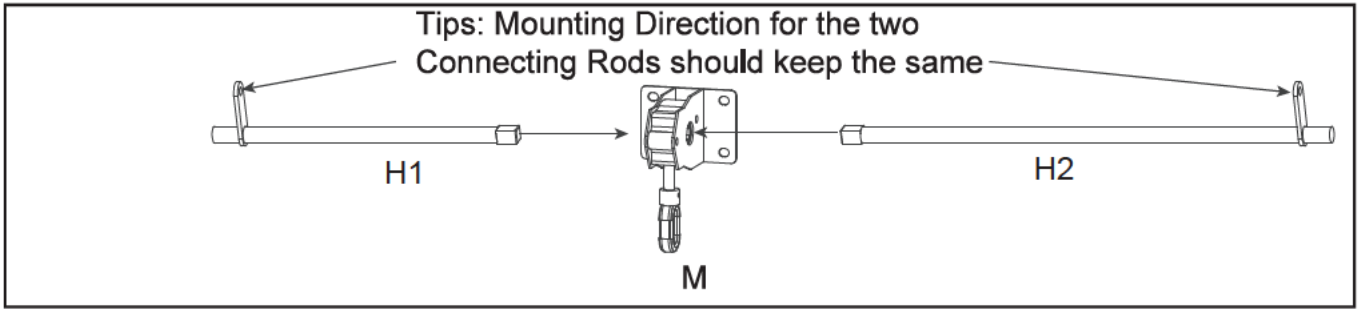

Figure 6.1

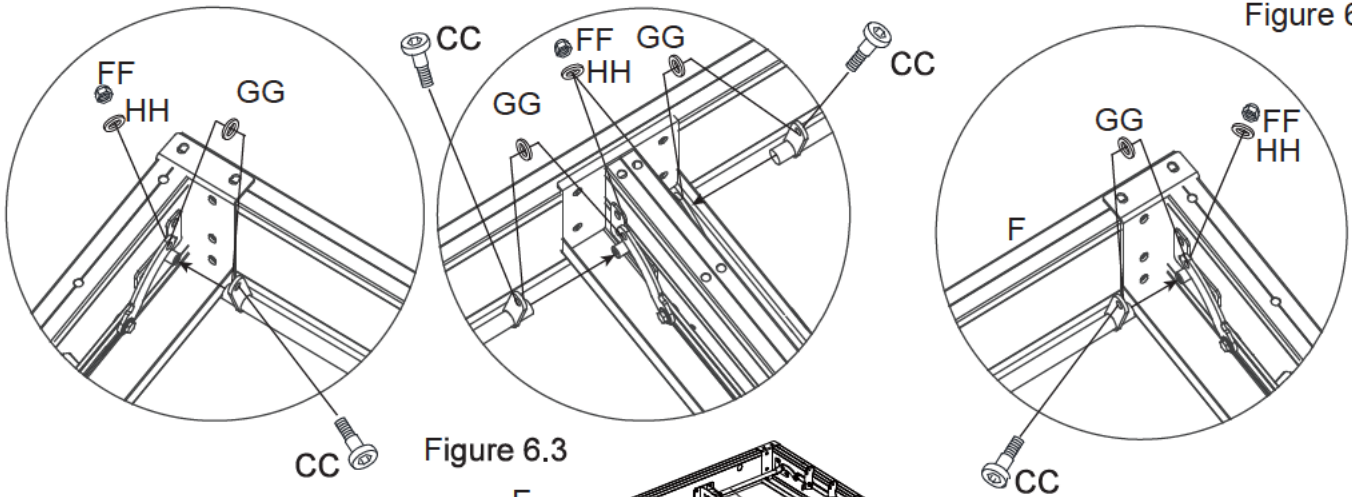

Figure 6.3

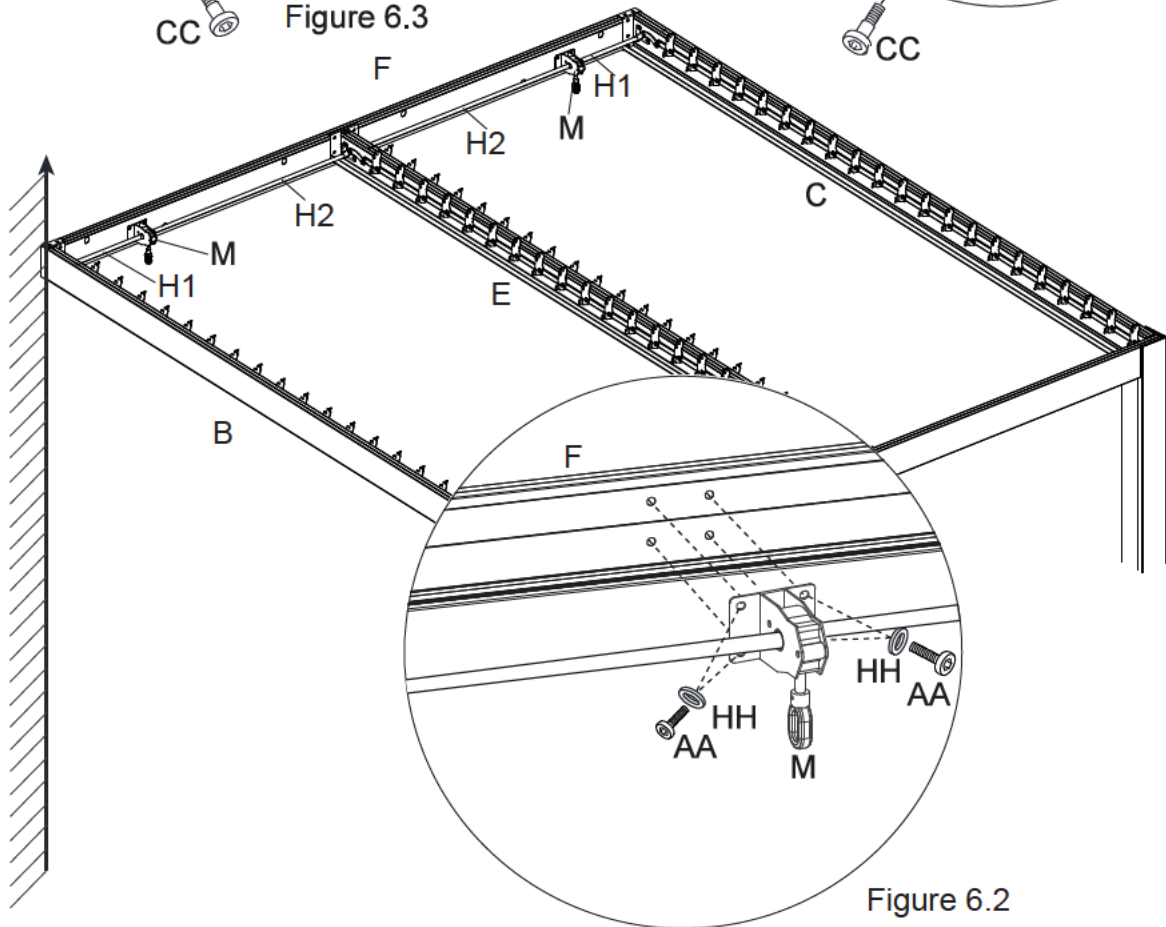
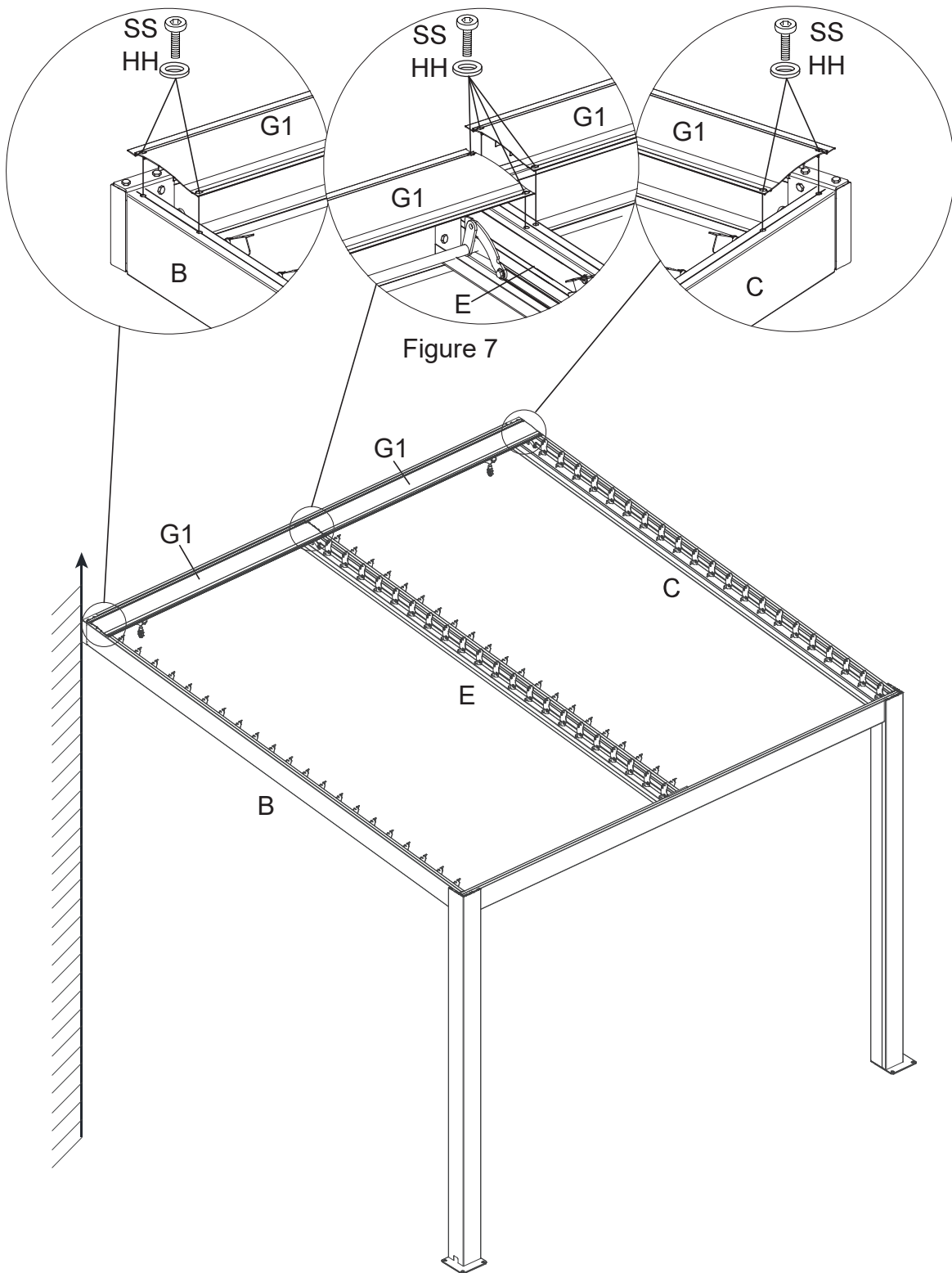

Figure 6.2

6. Insert one side of the two Connecting Rods (H1/H2) into the Spinner (M) and the other side into the Spinner (M), then attach the Spinner (M) to the Rear Lintel (F) and secure it with the Bolts (AA) and Washers (HH). Finally the other end of the Connecting Rods (H1/H2) is attached to the Lintels (B/C/E) using Bolts (CC), Washers (GG/HH) and Nuts (FF). See Figure 6.1- 6.3.

Step 7



7. Connect the Cover Plate (G1) to the Lintels (B/C/E), securing it with Bolts (SS) and Washers (HH). See Figure 7.

Step 8

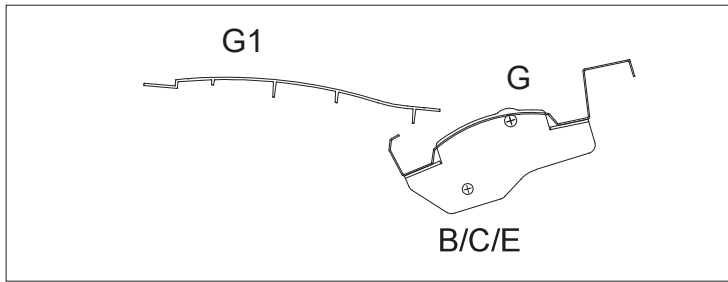

When installing the louver, please adjust the louver connector to about this Angle is more appropriate.

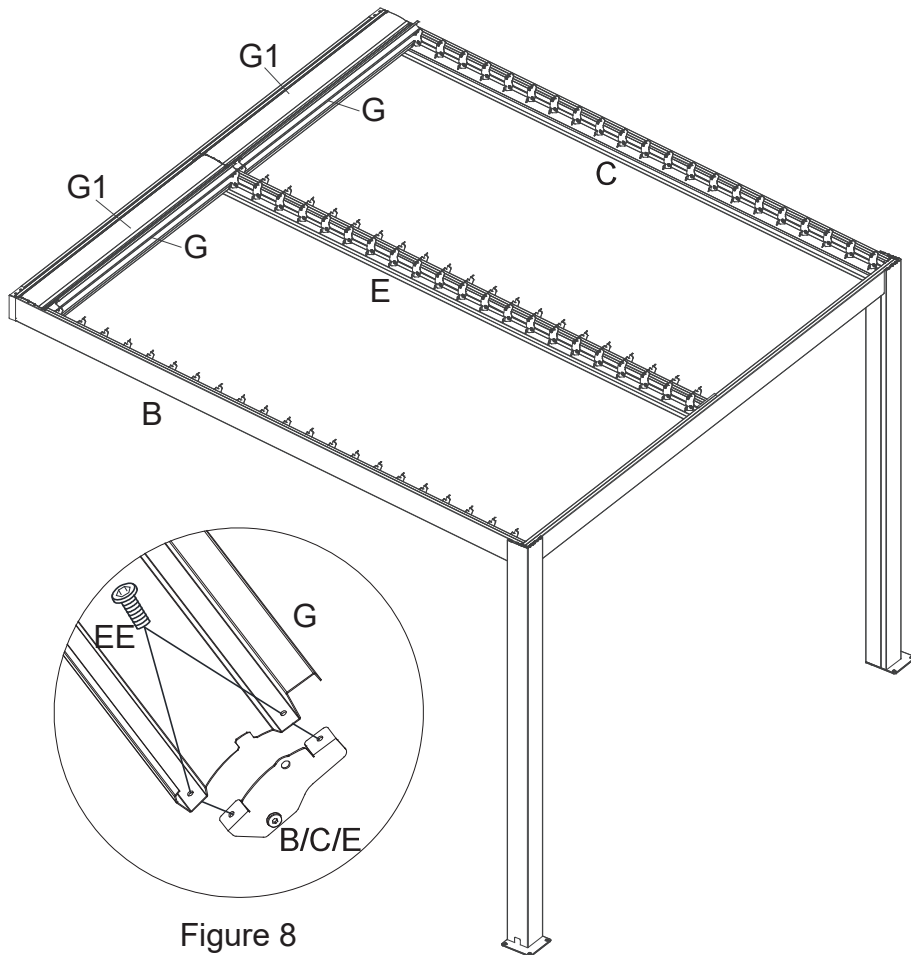
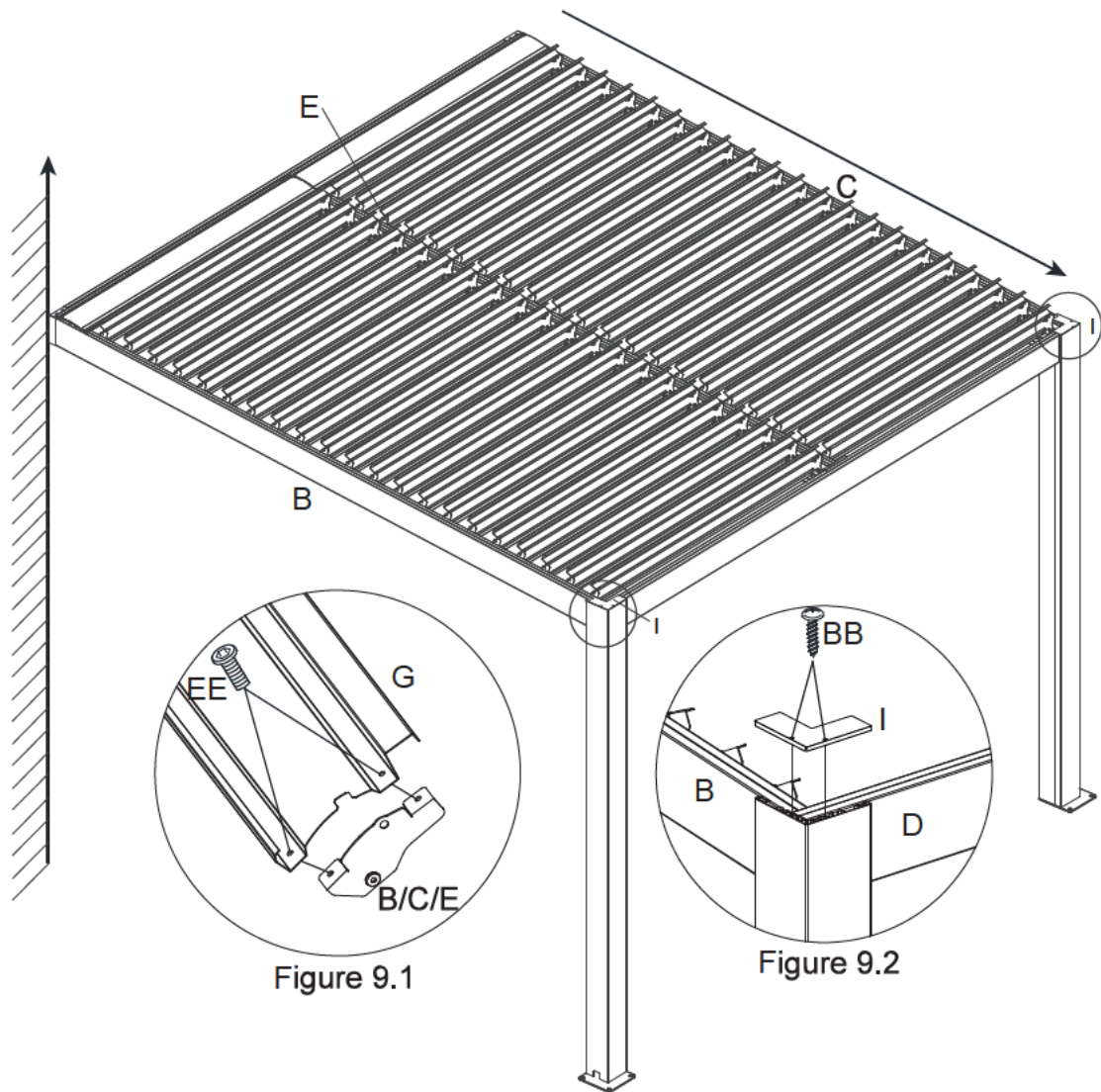
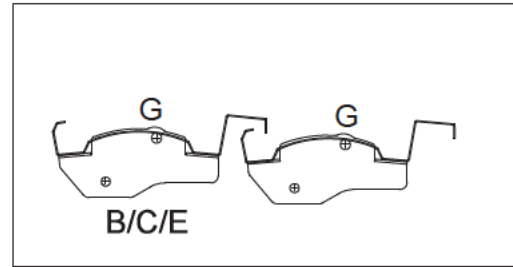
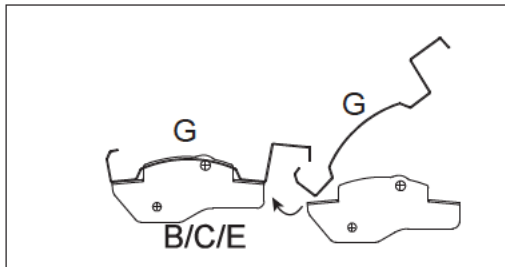
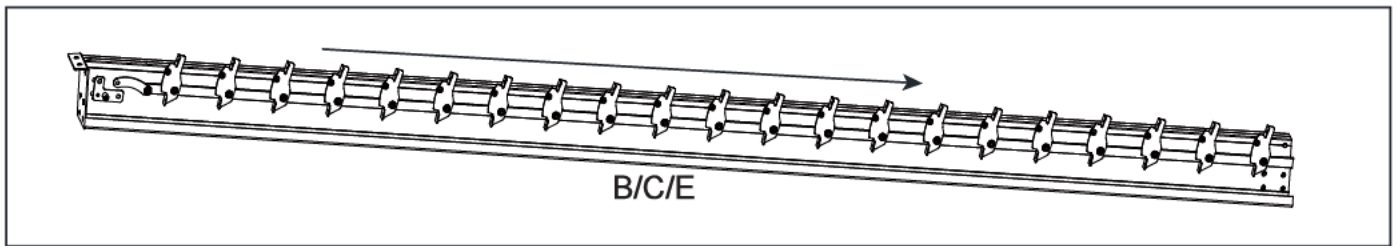

Figure 8

8. Connect the Louver (G) to the Lintels (B/C/E) and secure with the Bolts (EE). See Figure 8.

Step 9



9.1 Assemble the other Louvers (G) in the direction of the arrows and secure them with Bolts (EE). See Figure 9.1.

9.2 Connect the Cap Liner (I) to the Post (A) and secure with Bolts (BB). See Figure 9.2.

Step 10

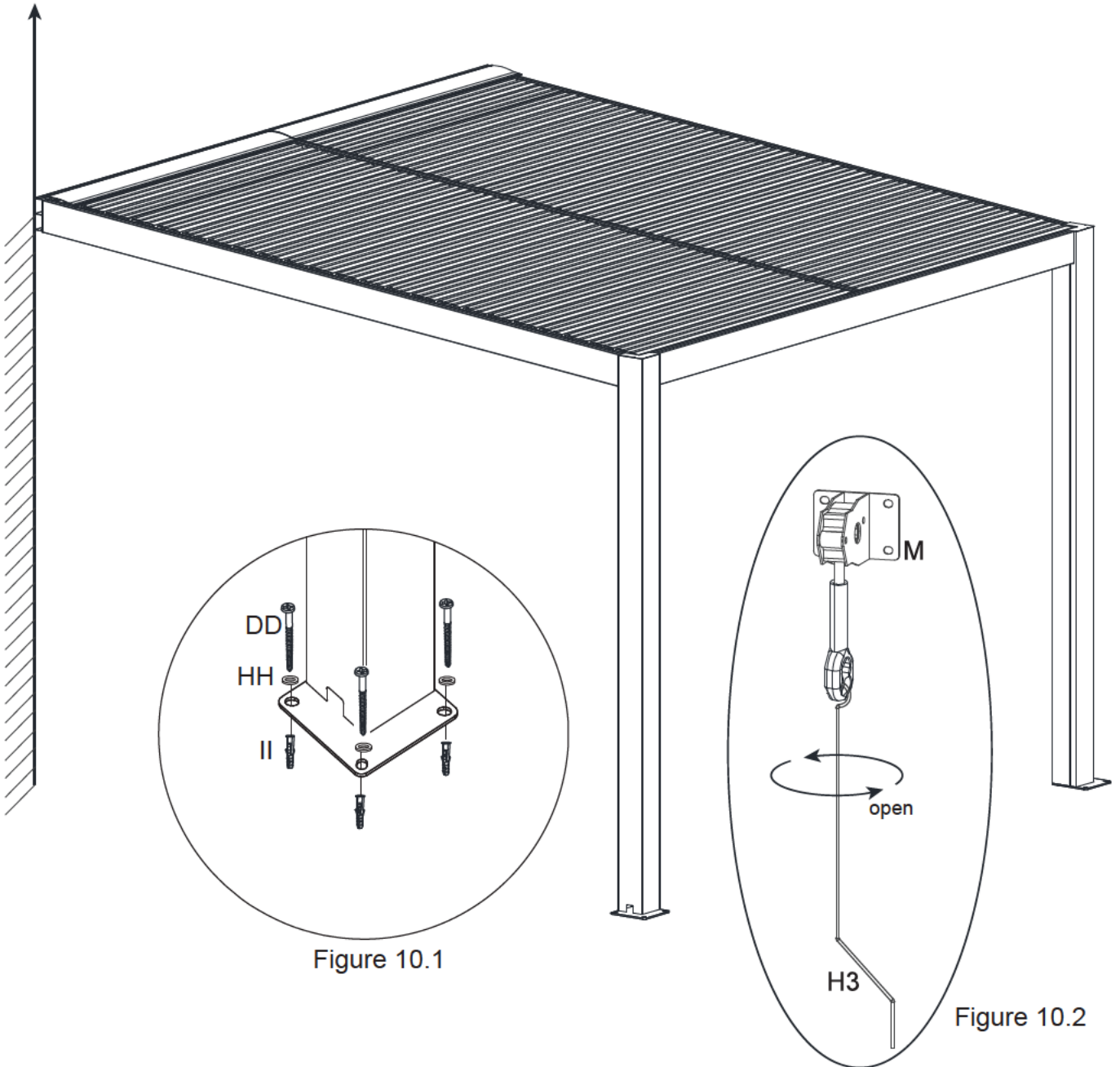

Figure 10.1

Figure 10.2

10.1 Secure the Pergola to the base plate using Screws (DD), Washers (HH) and Plastic plugs (II) to keep the Pergola secure. See Figure 10.1.

10.2 Hang the Crank (H3) on the Spinners (M) and turn to open or close the louvers. See Figure 10.2.

Warm Tips:

Please close the louvers when it rains.

Note: After the rain, please open the louvers slowly to prevent the residual rain water from splashing.

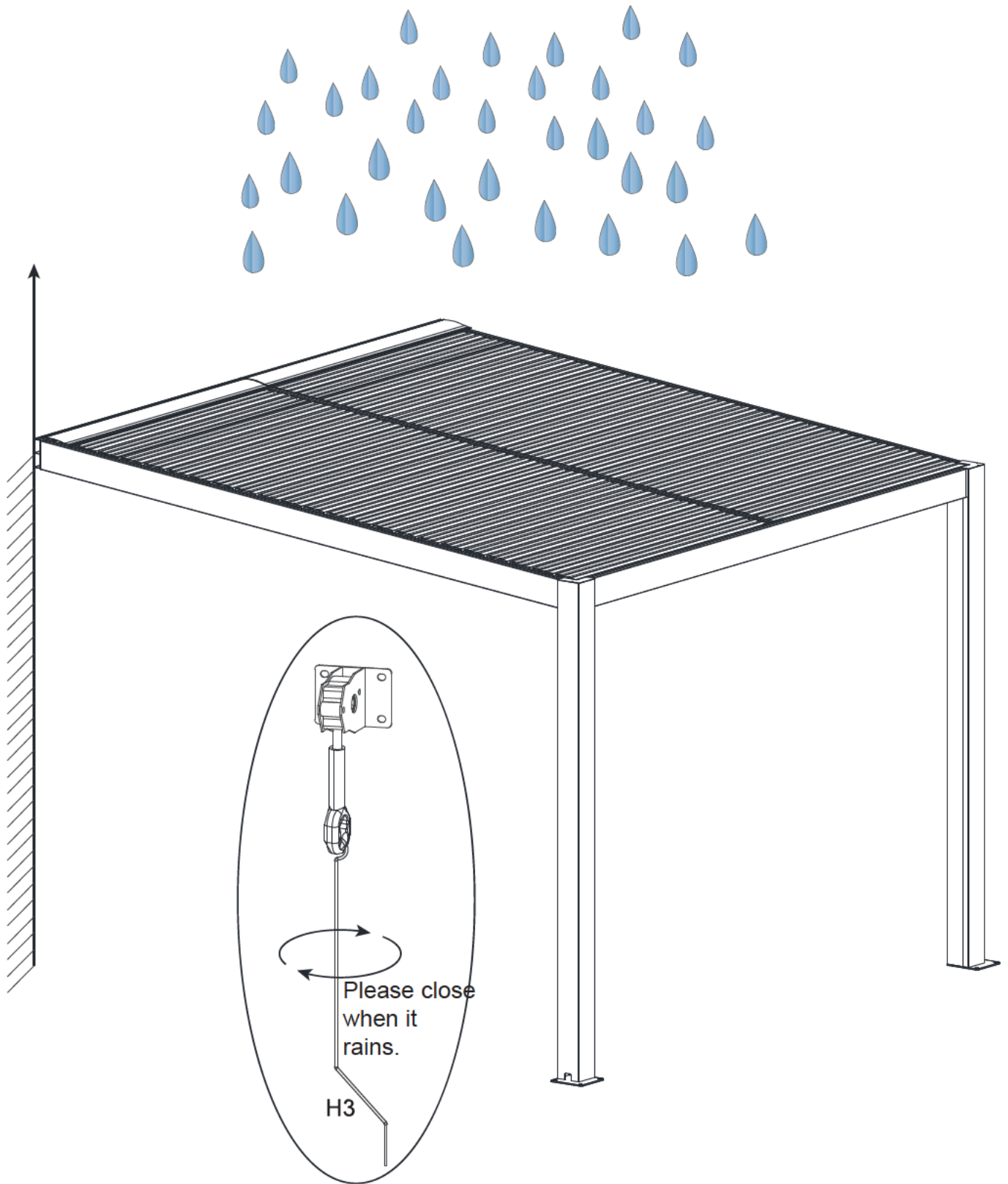

WARRANTY

WARRANTY

Carefully inspect the contents of the package for missing or damaged components. If any parts are missing or damaged, **do not return the product to the place of purchase**; instead, contact the Gazebo Penguin Customer Experience Department

Montreal: (514) 276-5643

Elsewhere in Canada and the United States: 1-800-737-7174

info@gazebopenguin.com

This product has been designed and manufactured to meet the highest standards of quality and durability. Subject to the "Warranty Conditions" and "Warranty Limitations" sections below, it is warranted against defects in material or workmanship for:

- **1 YEAR ON MANUFACTURING DEFECTS**

In the event that the product is damaged or the warranty period has expired, please contact the Penguin Gazebo Customer Experience Department for a complete list of replacement parts and prices.

WARRANTY LIMITATIONS AND EXCLUSIONS

1. This product is not warranted against damage caused by wind, falling objects, fire, animals, vegetation, vandalism and extreme weather conditions.
2. Collapses of shelters caused by snow, ice and wind accumulation
3. The roof **must be kept free of snow and ice accumulation at all times.**
4. Any damage that may be caused by snow and ice accumulation is not covered by the warranty. Snow and ice must be removed from the roof, from right to left, in five feet (5) sections at a time.
5. Removal of snow and ice from the product from the inside may damage the product and may cause serious injury to the person(s) involved in the removal.
6. It is strongly recommended that the product not be placed adjacent to buildings or trees as snow or ice may slide off the roof. In the event that the product is placed adjacent to a building or tree, additional precautions must be taken to ensure that there is no accumulation of snow or ice that could cause excessive weight to the product.
7. The product is warranted only if installed in accordance with Gazebo Penguin's written instructions included with the product.
8. Leaks due to heavy rainfall may occur. Please refer to the instruction manual for window positions and information on how to drain water.
9. The product is not guaranteed if it has been anchored improperly.
10. We reserve the right to replace or repair any defective product or part at our sole discretion.
11. No modifications or additions to the product are permitted. This will void your warranty.

Qty	Botanical Name	Common Name	Size/Condition	Remarks
Trees				
1	Betula Platyphylla 'Jefpark'	PARKLAND PILLAR BIRCH	60MM	
1	Malus Spring Snow	SPRING SNOW CRABAPPLE	60MM	
Shrubs				
1	Amelanchier Alnifolia 'Obelisk'	STANDING OVATION	5G	
1	Cornus sericea 'Farrow'	ARCTIC FIRE RED TWIG DOGWOOD	5G	
3	Hydrangea Paniculata 'Jane'	LITTLE LIME HYDRANGEA	5G	
1	Juniperus Horizontalis 'Blue Chip'	BLUE CHIP JUNIPER	5G	
4	Physocarpus Opulifolius 'Donna May'	LITTLE DEVIL NINEBARK	5G	
3	Spiraea Japonica Spirea	GOLDMOUND SPIREA	2G	
1	Syringa Bloomerang	BLOOMERANG LILAC	5G	

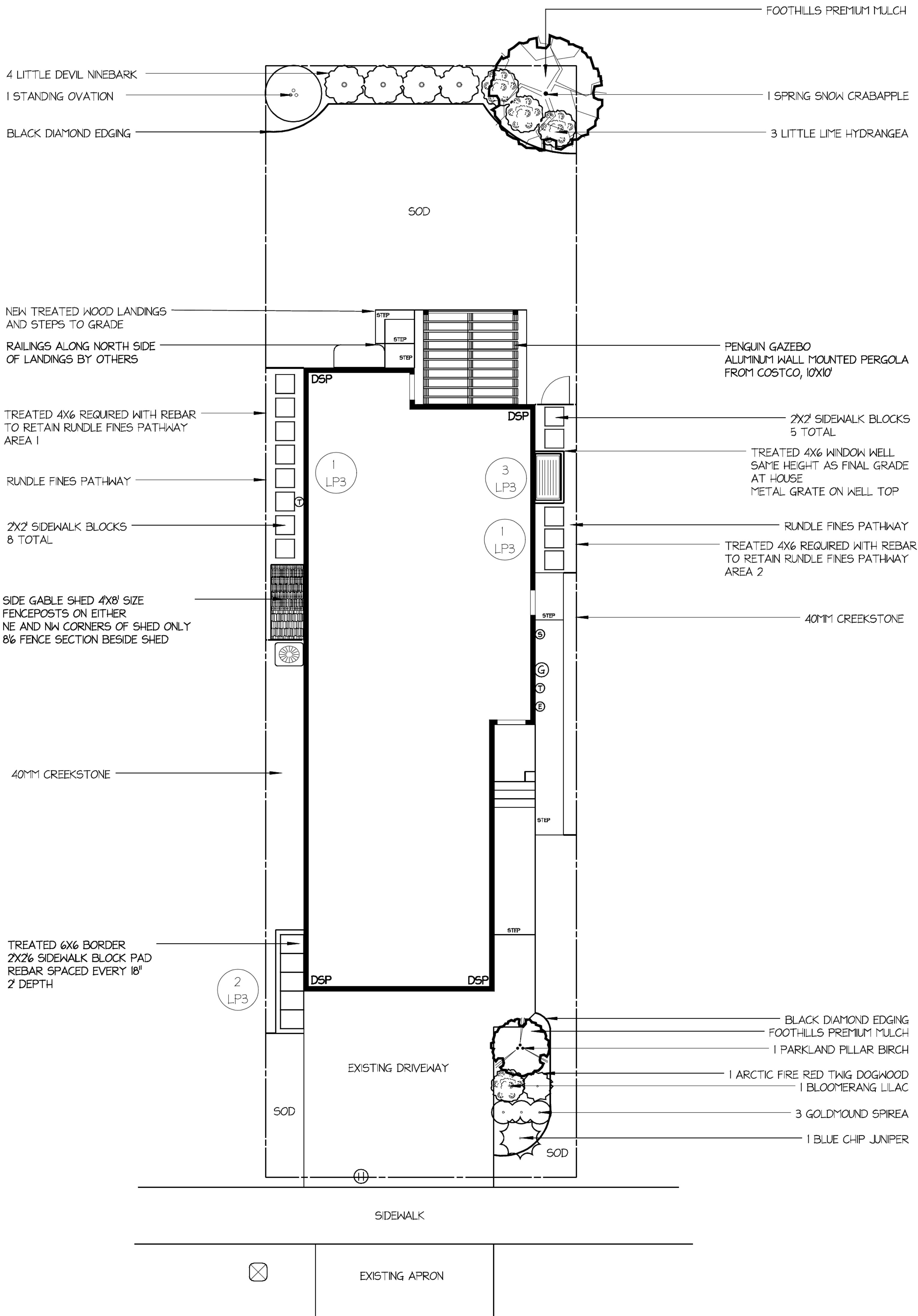

NOTES

1. ADDITIONAL PRICE OPTION TO REPLACE RUNDLE FINES PATHWAYS WITH 20MM SILVERSTONE 3" DEPTH WITH 50Z FABRIC BELOW 2X2 SIDEWALK BLOCKS SAME LAYOUT INSET INTO SILVERSTONE
2. FOOTHILLS PREMIUM MULCH TO BE 6" DEPTH, NO FABRIC
3. 40MM CREEKSTONE AREAS TO BE MIN. 3" DEPTH WITH 50Z FABRIC BELOW
4. 2 SCREW PILES RECOMMENDED TO BE INSTALLED UNDER NEW WOOD LANDINGS FROM DECK TO GRADE LAST STEP TO BE SET ON TREATED 6X6 SET INTO GROUND.
5. REFER TO CONSTRUCTION DETAIL PLAN FOR INSTALLATION OF PLANTS, RUNDLE FINES AREAS, SIDEWALK BLOCK LANDING AND WINDOW WELL AS PER DETAILS.
6. SOD REQUIRES A MINIMUM DEPTH OF 4" OF TOPSOIL DURING INSTALLATION AND SOIL MUST BE SOD ROLLED BEFORE AND AFTER SOD INSTALLATION. WATERING REQUIRED IMMEDIATELY AFTER SOD INSTALLATION.

No.	Date	Description
REVISIONS		



25415 TWP ROAD 544
ST, ALBERT, AB T8T-1M4
P: (780)460-1294 INFO@WLDCA.COM

LP3:
CONSTRUCTION PLAN

RAMNANAN RESIDENCE
98 ELDRIDGE POINT
T8N 8C4
ST. ALBERT, AB

SCALE	1" = 6'
DRAWN BY	J ELLERBECK
CHECKED BY	J ELLERBECK
DATE	APR 20-26
DATE OF PRINT	APR 20-26

PROJECT NO.	1228
SHEET NO.	3/3

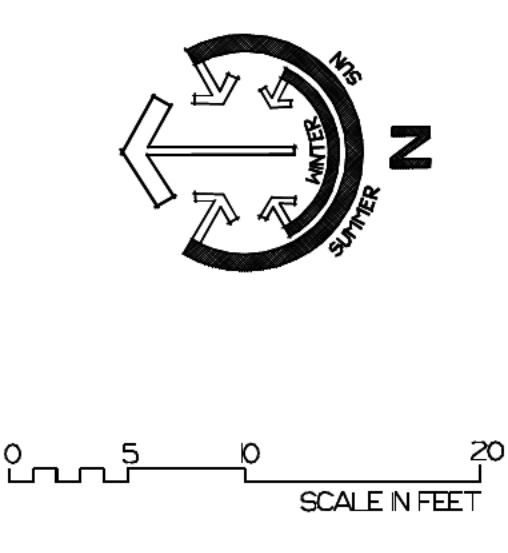

WALLMOUNTED PERGOLA MURALE 10X10 PAW1010

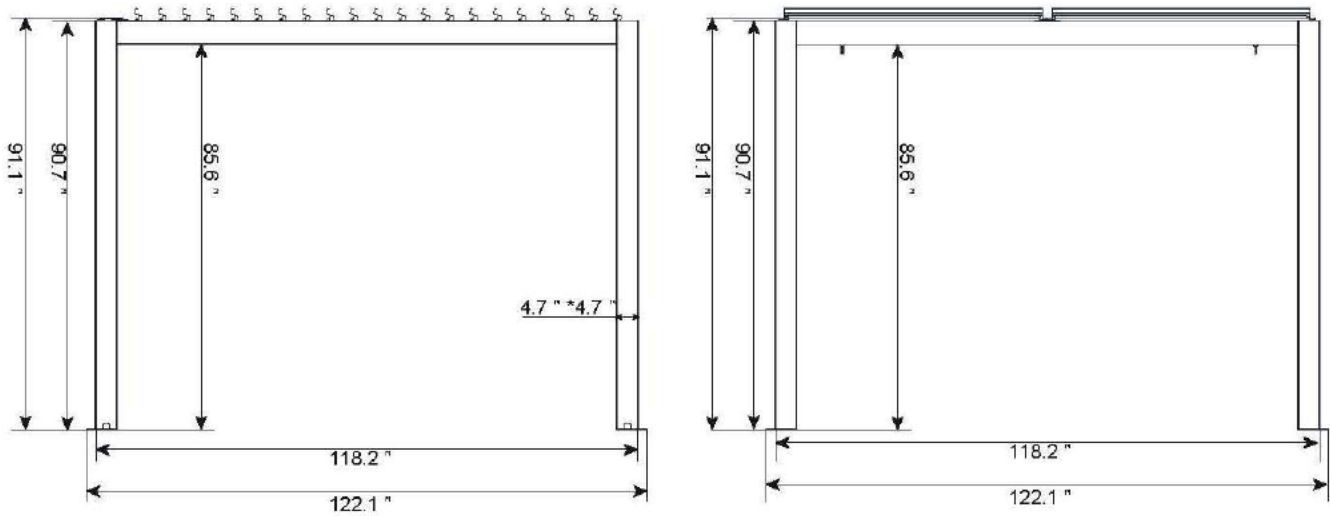

VUE DE CÔTÉ | SIDE VIEW

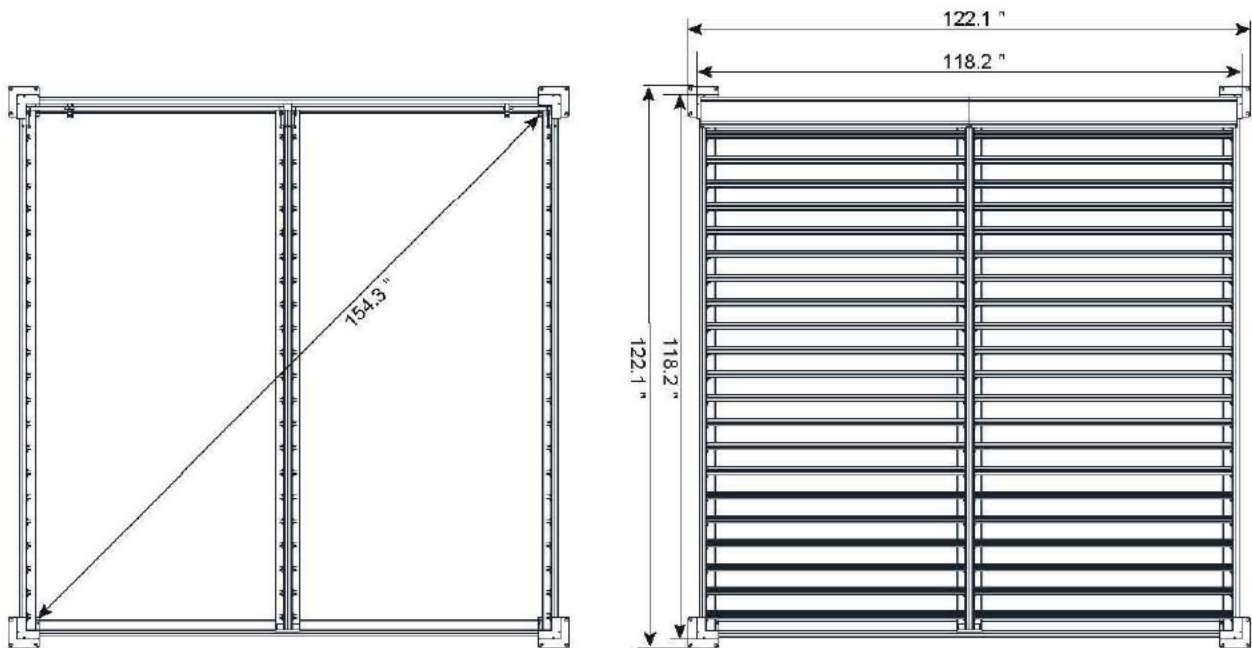

VUE DE LA BASE DE LA STRUCTURE
VIEW OF STRUCTURE BASE

VUE DU TOIT | ROOF VIEW

WALL MOUNTED PERGOLA MURALE 10X10 PAW1010

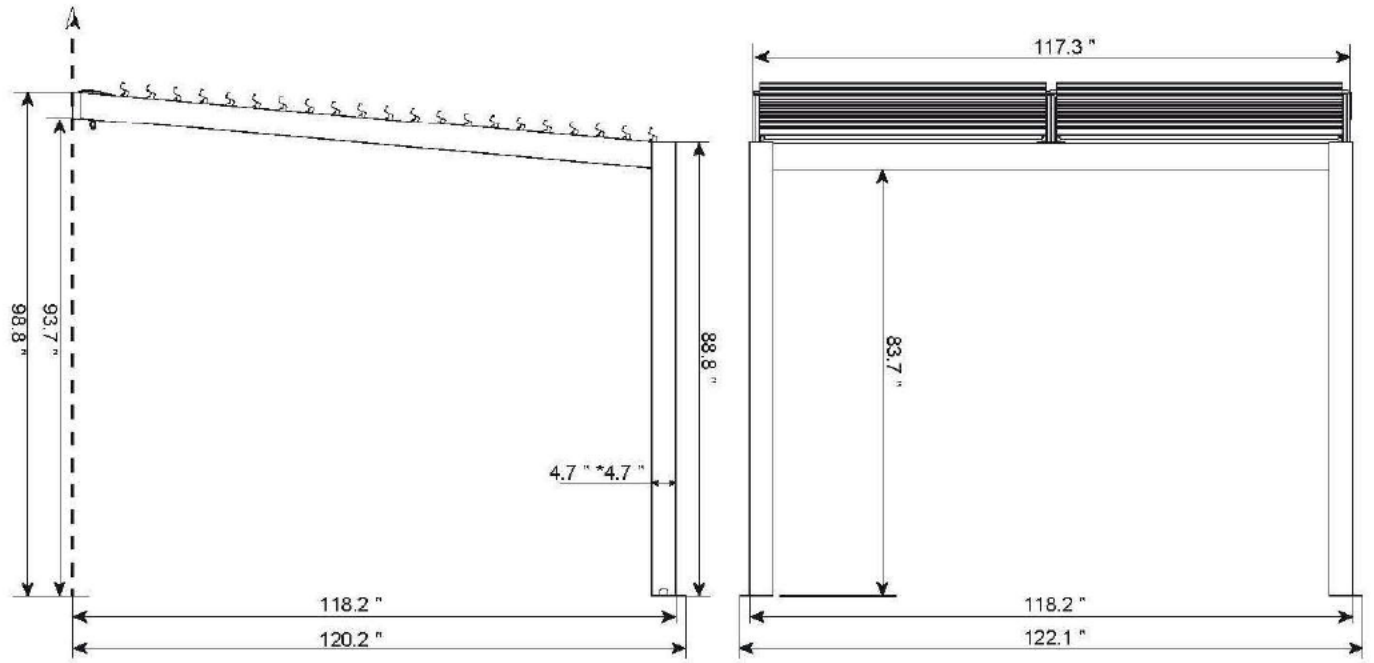

VUE DE CÔTÉ | SIDE VIEW

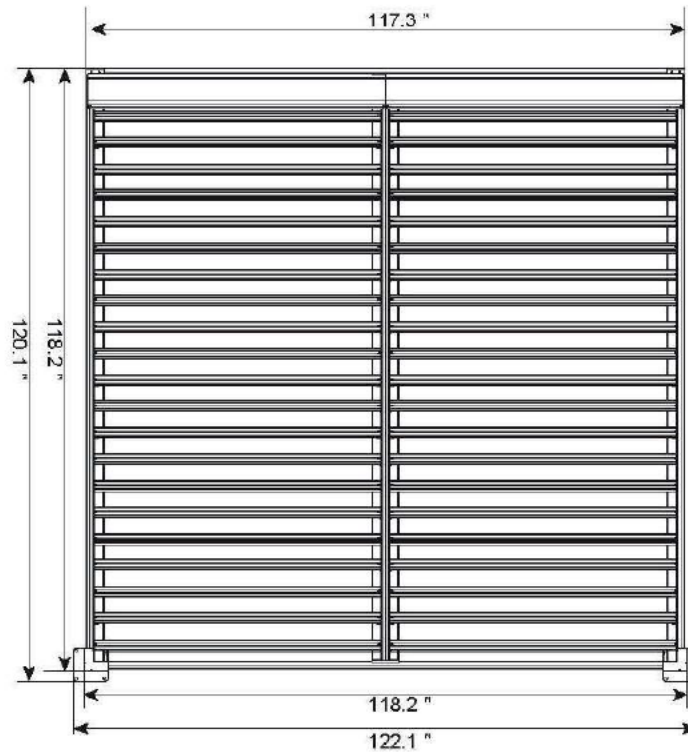

VUE DU TOIT | ROOF VIEW